

# Can Piercing Gauges

## Application

Vacuum / pressure test at cans, beverage cans, bottles, etc.; the test connection for cans is preferentially mounted on pressure gauge model RCh 63-1 (data sheet 1211).

## Standard Version

### Accuracy (EN 837-1)

Class 1.6

### Case and Ring

Bayonet ring case (model RCh) made of 1.4301 (304 stainless steel), tight bayonet ring; others upon request (only without filling)

### Protection Type (EN 60 529 / IEC 529)

IP 54 dry pressure gauges

### Nominal Case Size

63 mm (2½")

### Pressure Ranges (EN 837-1)

-1 – 0 bar	30" Hg vac. – 0
-1 – 0 – 0.6 bar	30" Hg vac. – 0 – 15 psi
-1 – 0 – 1.5 bar	30" Hg vac. – 0 – 30 psi

### Pressure Limitation

at steady load:  $\frac{3}{4}$  of the full scale value  
at dynamic load:  $\frac{2}{3}$  of the full scale value  
short-time: full scale value

### Connection

M 12 x 1.5 (0.47" x 2.17") bottom connection brass with cannula connection, needle  $\varnothing$  5 mm (0.2"), rubber seal made of NBR (nitrile rubber)

### Bourdon Tube

Bronze, c-form, soft soldered

### Window

Instrument glass

### Movement

Brass / German silver

### Dial

Aluminum, black figures, white background

### Pointer

Aluminum, black

### Safety Features

Blow-out plug at the top of the case

## Ordering Information (model construction):

Please state in your order:

Model:	<b>RCh</b>
Nominal case size:	<b>63</b>
Material code number for wetted parts:	<b>-1</b>
Pressure range:	-1 – 0 bar, -1 – 0 – 0.6 bar or -1 – 0 – 1.5 bar
Connection:	test connection for cans
Special versions:	(upon request)

### Example for ordering code:

RCh 63-1, -1/0 bar, test connection for cans

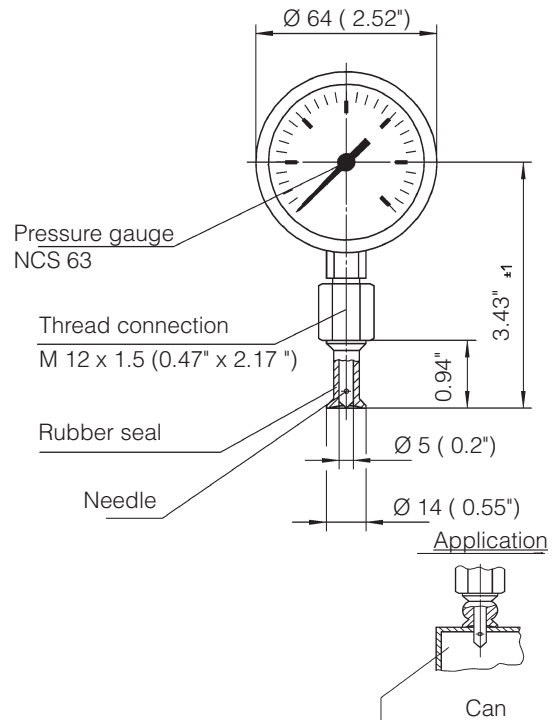

## Replacements

If required, the rubber seal can be ordered separately, item number: 643-500-012.

## Operating Instructions > B24 <

Before using the instrument, please make sure that the pointer is at zero.

The instrument has eventually to be ventilated by lifting the rubber seal at the can connection.

Afterwards, the rubber seal has to be adjusted that the needle is not visible. (This can be tested by touching the flange with the finger.)

To grant a good sealing, it is advisable to dampen the lower flange of the seal, which is attached to the can.

When attaching the pressure gauge onto the can, the needle must not pierce into the can at first. At first, the sealing has to be made by attaching the rubber closely.

Now the needle can be pierced into the can slowly by pushing the pressure gauge down. The vacuum (resp. the pressure) of the can is being indicated.

If vacuum occurs, the rubber closes the vent of the needle, when pulling it out. The indication lasts.

Please ventilate the instrument once again before a new measurement is made (see above).

For cleaning the connection, the rubber seal can be detached completely.



Instruments To  
Industry Ltd

## INSTRUMENTS TO INDUSTRY LTD

Euro Works - Hawksley Industrial Estate - Hawksley Street  
Oldham - OL8 4PQ - United Kingdom

T: +44 (0)161 652 7741

F: +44 (0)161 621 0389

E: sales@itiuk.com

W: www.itiuk.com