

# Diaphragm Seals threepart

Male Thread or Flange Connection, PN 40, optional PN 100

MDM

7210v...

## Standard Version

Information on applications, features, metrological influences as temperature, level difference, floating time and others can be found in model overview 7000. Furthermore you will also find advice on other chemical seal versions.

## Construction

The threepart construction (attachment flange, upper- and lower part) allows a combination of different materials and a selection of various process connections (male thread or flange connections), so that a wide range of application is given. The membrane is welded to the upper part.

Bourdon tube pressure gauges, pressure switches, pressure transmitters, pressure transducers and other pressure measuring instruments can be provided with diaphragm seals of this type series.

**Model 7210vG $\frac{1}{2}$**  has a measuring instrument adapter with female thread for direct mounting to measuring instruments with male thread.

The screwed connections pressure gauge / adapter and the filling port must not be loosened respectively opened, as otherwise filling fluid leaks and the measuring unit loses its efficiency.

**Model 7210vd8** has an orifice d8 for welding to a pressure gauge with process connection d8x5 as instrument connection, e.g. RCh 100-3vDW, cooling element or capillary line.

Leakage can not occur at the welded connection of pressure gauge / upper part and the filling port which is not accessible externally. The parts can be cleaned externally.

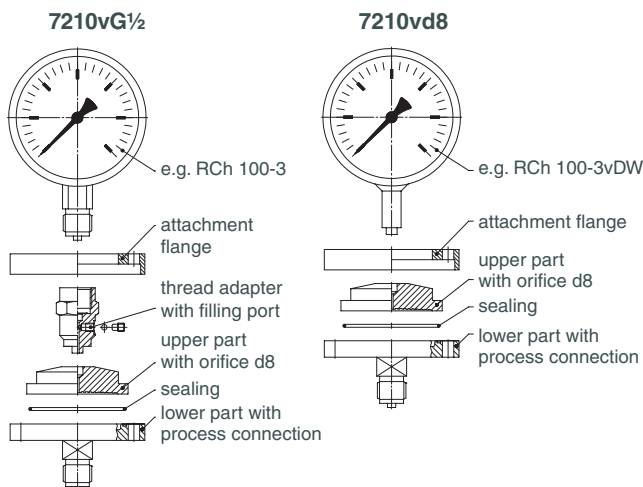

## Upper Part

1.4435 (316 L stainless steel)

## Instrument Connection

7210vG $\frac{1}{2}$ : G  $\frac{1}{2}$  female ( $\frac{1}{2}$ " BSP)  
7210vd8: orifice d8

## Membrane

High-Soft Membrane 1.4435 (316L stainless steel) welded with the upper part,

He-leak detection up to  $10^{-9}$  mbar l/s  
effective membrane diameter dM= 60 mm (2.36")

## Lower Part with Process Connection

316L (stainless steel), connection male thread G  $\frac{1}{2}$  B ( $\frac{1}{2}$ " BSP) material- and connection-options, see page 2



RK 100-3  
with MDM 7210vG $\frac{1}{2}$

RCh 100-3vDW  
with MDM 7210vd8



**Nominal Pressure**  
PN 40  
optional PN 100

PTMvDW  
with MDM 7210vd8

## Attachment Flange and Screws with Nuts

Made of galvanised steel, 6 screws and nuts M8;  
optional PN 100, 12 screws and nuts M8

## Minimum Span Pressure Gauges:

0.6 bar (10 psi) for bourdon tube pressure gauges NCS 100 and below  
for other measuring instruments: upon request

## $t_k$ -value (mbar/10K) (temperature coefficient of the chemical seal):

0.13 mbar / 10K (for silicone oil FA1)

## Special Versions among others

- Other instrument connections upon request, whereas we do not recommend NPT-female thread
- Other material combinations (process connection, membrane) than on page 2 upon request
- Calculation of temperature-related additional error for the whole measuring unit

## Accessory:

Capillary line, cooling elements: see data sheet 7002  
Other accessory: available upon request

## Mounting / Filling / Certificates:

Information on mounting and filling, reports and certificates are available upon request.

## Ordering Information Chemical Seals:

See page 2.

The reference temperature is +20 °C.

Please specify, if a +20°C deviating working temperature (tA) is required (dial inscription tA...).



Instruments To  
Industry Ltd

## INSTRUMENTS TO INDUSTRY LTD

Euro Works - Hawksley Industrial Estate - Hawksley Street  
Oldham - OL8 4PQ - United Kingdom

T: +44 (0)161 652 7741

F: +44 (0)161 621 0389

E: sales@itiuk.com

W: www.itiuk.com

7210

09/12

## Further Options regarding Ordering Information

Basic Models:		Diaphragm seals as threepart construction type PN 40, optional PN 100				MDM 7210v
Instrument Connection:	G ½ female					7210vG ½
	option: G ¼ female					7210vG ¼
	orifice d8 for direct welding with measuring instrument,					7210vd8
	with cooling element or with capillary line					
Chemical Seal:		<b>Lower Part</b>	<b>Sealing</b>	<b>Membrane</b>		
		with process connection				
Upper part: 1.4435 (316L stainless steel)	<b>Standard</b>					
	<b>316 L stainl. steel</b>	316L stainless steel	FPM (Viton®) (-20 °C to +200 °C / -4 °F to +392 °F)	1.4435 (316L stainless steel)	<b>316L stainless steel, PN 40</b>	
Attachment flange and screws with nuts: steel galvanised (max. 200 °C / 392 °F)	<b>Options</b>					
	<b>Steel galvanised</b>	steel galvanised	NBR (Perbunan) (-30 °C to +100 °C / -22 °F to +212 °F)	1.4435 (316L stainless steel)	<b>Steel galvanised, PN 40</b>	
	<b>Steel / PTFE</b>	steel PTFE- lining		1.4435 (316L stainless steel)	<b>Steel / PTFE, PN 40</b>	
	<b>316 L stainless steel / PTFE</b>	stainless steel 316L PTFE- lining	–	PTFE protection foil <sup>1)</sup>	<b>316L Stainl. steel / PTFE, PN 40</b>	
	<b>Monel</b>	Monel 400 2.4360	PTFE (-40 °C to +260 °C / -40 °F to +500 °F)	Monel 400 2.4360	<b>Monel, PN 40</b>	
	<b>Hastelloy</b>	Hastelloy C4 2.4610		Hastelloy C276 2.4819	<b>Hastelloy, PN 40</b>	
	<b>Further options</b>					
	<b>PN 100</b>					
	<b>316 L stainl. steel</b>	316L stainless steel	–	1.4435 (316L stainless steel)	<b>e.g. 316L stainl. steel, PN 100</b> <b>e.g. 7210vd8vA stainl. steel</b> <b>316L, PN 40</b> (vA= welded version / drawing see page 3)	
	<b>Titanium</b>	Titanium 3.7035	PTFE (-40 °C to +260 °C / -40 °F to +500 °F)	Titanium 3.7035	<b>Titanium</b> (drawing see page 3)	
<b>Process Connection</b>						
Male Thread:	standard thread	G ½ B (½" BSP)				<b>G ½ B (½" BSP)</b>
	options:	½" NPT (for PTFE-lining not recommended) M 20x1.5				<b>½" NPT</b> <b>M 20x1.5</b>
Flange:		<b>DN</b>	<b>PN</b>	<b>NPS</b>	<b>Class</b>	
		15 20 25 50	40	NPS ½" NPS ¾" NPS 1" NPS 2"	Class 150	<b>DN15 PN40</b>
		15 25 50 50	63/100 63 100	NPS ½" NPS ¾" NPS 1" NPS 2"	Class 300	<b>NPS1" Class 300</b>
		sealing face acc. to DIN EN 1092-1		sealing face acc. to ASME B 16.5		
		PN 40 Form B1 PN 63/100 Form B2				
Further Options:	membrane made of	1.4571	Stainless steel			<i>(order at the moment still as cleartext)</i>
		1.4539	Uranus B6			
	1.4462	Duplex				
	2.4610	Hastelloy C4				
	2.4819	Hastelloy C276				
	2.4856	Inconel 625				
	2.4360	Monel 400				
	2.4068	Nickel				
	–	Tantal (≤ 250 °C / 482 °F)				
	3.7035	Titanium <sup>3)</sup>				
	others	upon request				
	other sealings, e. g.:	up to -60 °C (-76 °F) upon request				
	protection foil for	fine silver <sup>1)</sup> PTFE <sup>1)</sup>				
	orifice Ø 10 mm (0.4")	for thread connection (standard for PTFE-lining <sup>2)</sup> )				
	attachment flange and screws with nuts (max. 400 °C / +752 °F)	stainless steel		PN 40 PN 100		
	flanges	for DIN EN 1092-1		nut or elastic element various forms male- and female face various forms		
		for ASME B16.5		Class 600 upon request UNC-thread upon request RJF-circular groove according to other standards upon request		
	stud screws M 12 x 35 for open flanges according to DIN EN, DN 15, 20 or 25					
<b>Examples:</b>	<b>MDM 7210vG ½, steel galvanised, PN 40, G ½ B / MDM 7210vd8, 316L stainl. steel, PN 100, DN 50 PN 63</b>					

<sup>1)</sup> Temperature resistance max 260°C (500 °F), max. 100 bar, for use under vacuum up to 100 °C (212 °F)

<sup>2)</sup> Orifice Ø 10 mm (0.4") outside of lining, with lining approx. Ø 7 mm ( 0.28")

<sup>3)</sup> Upper part und diaphragm Titanium

# Dimensional Data and Weights

## Male Thread Connections

G 1/2 B (1/2" BSP)

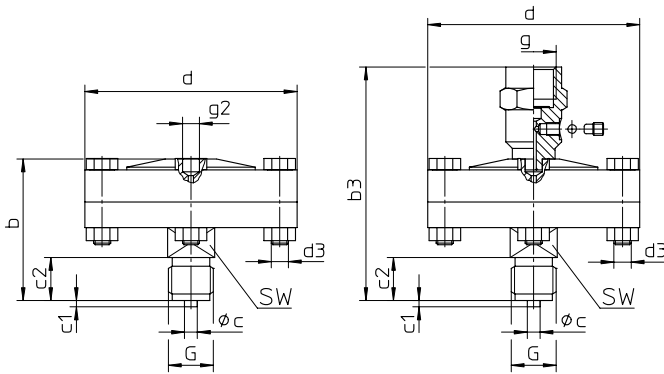

1/2 NPT

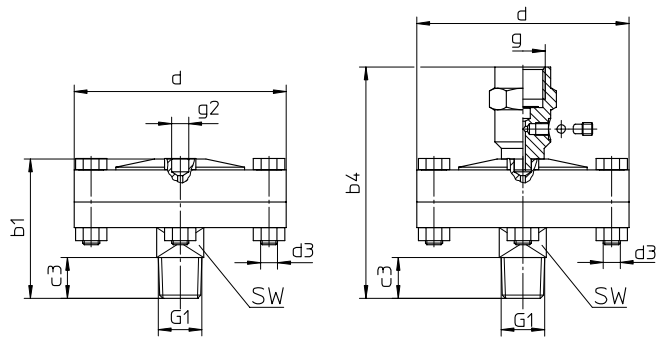

### Dimensional data (mm / inches) and weights (kg / lb)

PN	b <sup>±2</sup>	b1 <sup>±2</sup>	b3 <sup>±2</sup>	b4 <sup>±2</sup>	c	c1	c2	c3	d	d3	dM	g	g2	G	G1	SW	(approx.) weight	
																	vG 1/2	vd8 x 5
40	66	65	109	108	6	3	20	19	99	6 x M8	60	G 1/2	Ø 8 x 6	G 1/2 B	1/2" NPT	22	1.71	1.58
	2.6	2.56	4.29	4.25	.24	.12	.79	.75	3.9		2.36	1/2" BSP	Ø 8 x .24	1/2" BSP		.87	3.77	3.48
100	66	65	109	108	6	3	20	19	99	12 x M8	60	G 1/2	Ø 8 x 6	G 1/2 B	1/2" NPT	22	1.83	1.70
	2.6	2.56	4.29	4.25	.24	.12	.79	.75	3.9		2.36	1/2" BSP	Ø 8 x .24	1/2" BSP		.87	4.03	3.75

## 7210 vd8vA

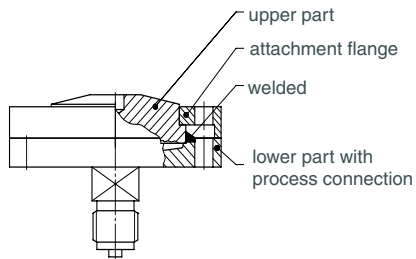

## Titanium

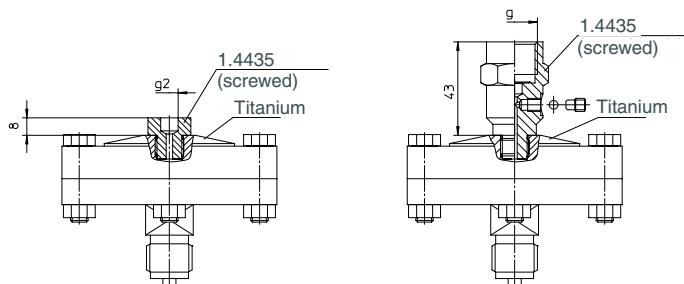

Please use our "Check list for pressure measuring instruments with chemical seal" for ordering, to avoid disregarding important information (see PDF-Download area on our website). If desired, we will send you the check lists upon request.

# Dimensional Data and Weights

## Flange Connections

DIN-flanges sealing face DIN EN 1092-1 / ASME-flanges sealing face ASME B16.5

DN 15, 20, 25  
NPS ½", 1"

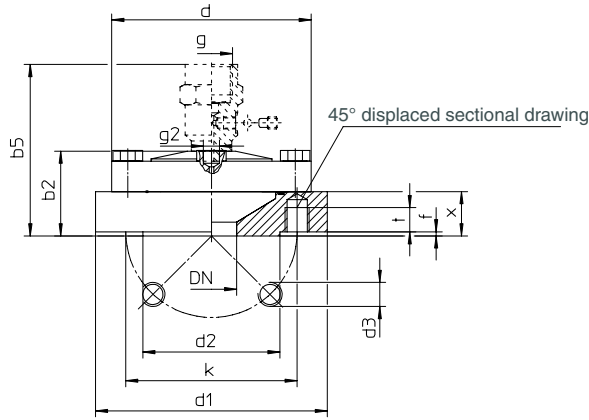

DN 50  
NPS 2"

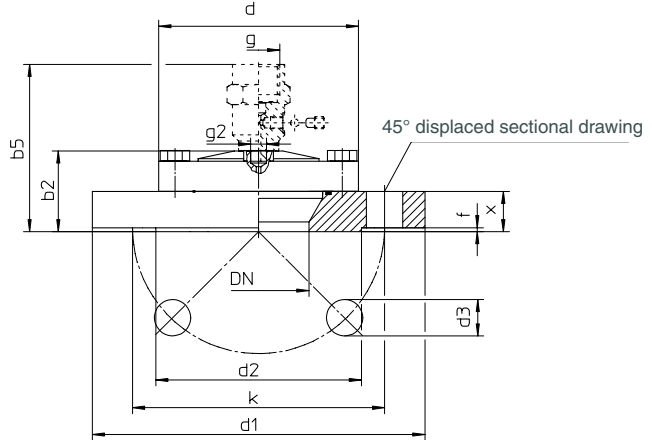

Flanges according to DIN EN 1092-1, dimensional data (mm / inches) and weights (kg / lb)

DN	PN	b2±2	b5±2	d	d1	d2	d3	f	g	g2	k	t	x	(approx.) weight						
														vG ½	vd8 x 5					
15	40	45 1.77	88 3.46	99 3.9	99 3.9	45 1.77		2 .08	G ½ ½" BSP	Ø 8x6 Ø 8x.24	65 2.56	12 .47	25 .98	2.12	1.99					
	63/100	60 2.36	103 4.06		105 4.13	75 2.95					18 .71	40 1.57	3.32	3.19						
20	40	45 1.77	88 3.46		58 2.28	4xM12					12 .47	25 .98	2.26	2.13						
	63/100	67 2.63	110 4.33		130 5.12						90 3.54	18 .71	47 1.85	5.23	5.10					
25	40	42 1.65	85 3.35		68 2.68						115 4.53	4xØ18 4xØ.71	85 3.35	12 .47	22 .87	2.39	2.26			
	63/100	60 2.63	103 4.06		140 5.51						100 3.94		18 .71	40 1.57	5.23	5.10				
50	40	40 1.57	83 3.27		165 6.5		102 4.02				125 4.92			3		Ø 8x6 Ø 8x.24	20 .79	19 .75	3.58	3.45
	63	46 1.81	89 3.5		180 7.09						135 5.31						26 1.02		5.13	5.00
	100	48 1.89	91 3.58		195 7.68	145 5.71					28 1.10						6.25		6.12	

Flanges according to ASME, dimensional data (mm / inches) and weights (kg / lb)

NPS	Class	b2±2	b5±2	d	d1	d2	d3	f	g	g2	k	t	x	(approx.) weight				
														vG ½	vd8 x 5			
½"	150	60	103	99 3.9	99 3.9	35.1 1.38	4 x ½" -20 UNF - 2 B	1.6 .06	G ½ ½" BSP	Ø 8x6 Ø 8x.24	60.5 2.38	19 .75	40 1.57	2.91	2.78			
	300	65 2.56	108 4.25								66.5 2.62			45 1.77	2.95	2.82		
	600	79.2 3.12	40 1.57								3.36			3.23				
1"	150	60	103		108 4.25	50.8 2		4 x ⅝" -18 UNF - 2 B			1.6 .06		40 1.57	Ø 8x6 Ø 8x.24	19 .75	40 1.57	4.16	4.03
	300	65 2.56	108 4.25		88.9 3.5											45 1.77	4.25	4.12
	600	120.7 4.75	45 1.77		9.37											9.08		
2"	150	39.1 1.54	82.1 3.23		152.4 6.0	91.9 3.62	8 x Ø 19 8 x Ø.75				1.6 .06	127 5.0	Ø 8x6 Ø 8x.24		19.1 .75	3.11	2.98	
	300	42.4 1.67	85.4 3.36		22.4 .88												3.76	3.63
	600	51.8 2.04	94.8 3.73		31.8 1.25												4.54	4.41

Changes, replacement of materials and printing errors excepted.