

Diaphragm Pressure Gauges

Accuracy Class 1.6

Models

PSCh
PSChG

Safety Bayonet Ring Case Stainless Steel, Solid Front, Blow-out Back
Standard (PSCh) or with Case Filling (PSChG)

NCS 100 (4"), 160 (6")

Applications

Pressure gauges with horizontal diaphragm allow to find suitable versions even for difficult media, such as aggressive, contaminated, or viscous fluids. Safety bayonet ring case (solid front and blow-out back) especially for applications where a sealed case is required, and/or chemical resistance and high safety standards.

Nominal Case Size (NCS)

100 mm (4") and 160 mm (6")

Accuracy Class (EN 837-3)

1.6 (i.e. $\pm 1.6\%$ f.s.), versions with protection foil on the diaphragm and model PSChG with manovacuum compound ranges ≤ 250 mbar accuracy class 2.5

Pressure Ranges (EN 837-3)

PSCh: 0- 10 mbar (0- 4" WC) up to 0-40 bar (0-600 psi)

PSChG: 0-160 mbar (0-60" WC) up to 0-40 bar (0-600 psi)

also corresponding vacuum and compound ranges

Pressure Limitations (EN 837-3)

Steady pressure: full scale value

Cyclic pressure: 90% of full scale value

Overpressure: up to 5 times f.s., but max. 40 bar (600 psi), resp.
2.5 bar (40 psi) for measuring flange $\varnothing 160$ mm (6")

Protection Type (EN 60 529 / IEC 529)

Model PSCh: IP 54 / model PSChG: IP 65

Further information about advantages, applications, specifications, temperature limitations and pressure ranges of diaphragm pressure gauges can be found in our model overview **3000**.

Standard Configuration

Process connection

Bottom thread connection $\frac{1}{2}$ " BSP (standard), $\frac{1}{2}$ " NPT or M 20x1.5; versions -4 and -5 with inlet port \varnothing approx. 7 mm (.28"), flange connection at option, compare following pages

Wetted Parts

- 3	Lower flange:	stainless steel 316 L
	Gasket:	FPM
	Diaphragm:	10 to 250 mbar: 316 Ti (1.4571) 0.4 to 40 bar: Duratherm (NiCrCo-alloy)
- 4	Lower flange:	carbon steel, zinc plated, PTFE-lined
	Gasket:	PTFE
	Diaphragm:	40 to 250 mbar: 316 Ti (1.4571), PTFE-foil 0.4 to 25 bar: Duratherm, PTFE-foil
- 5	Lower flange:	stainless steel 316 L, PTFE-lined
	Gasket:	PTFE
	Diaphragm:	40 to 250 mbar: 316 Ti (1.4571), PTFE-foil 0.4 to 25 bar: Duratherm, PTFE-foil

Upper Flange

304 stainless steel (1.4301)

Measuring Flange \varnothing

Pressure ranges ≤ 250 mbar (≤ 100 " WC): $\varnothing 160$ mm (6"),

Pressure ranges ≥ 400 mbar (≥ 160 " WC): $\varnothing 100$ mm (4")

Movement

Stainless steel

Dial

Aluminum alloy, black figures, white background

Pointer

Aluminum alloy, black

Case

Safety bayonet ring case 304 stainless steel (1.4301)

Filling Liquid

Model PSChG only: glycerine



Lens

Laminated safety glass

Safety Features

Safety case similar to S3 according to EN 837-1, solid front 304 stainless steel (1.4301) between measuring system and dial, and a full blow-out safety back

Venting

Model PSChG with direct venting to the atmosphere at case top

Optional Special Configurations

- Inlet port orifice up to $\varnothing 10$ mm (.39") for version -3
 - Other connection flanges upon request (e.g. according to former DIN),
 - Hygienic connection, e.g. according to DIN 11851, DN 25 to DN 50, with or without lateral cleaning valve (compare data sheets 7300, 7301)
 - Diaphragm with protection foil (vacuum tight):
 - PTFE (≥ 40 mbar), sealing PTFE;
 - Fine-silver (≥ 160 mbar), sealing FPM;
 - Tantalum (≥ 160 mbar), sealing PTFE; others upon request
 - Other materials lower measuring flange/process connection upon request
 - Upper measuring flange with body 316 Ti (1.4571)
 - Top or side connection, or other than vertical installation position
 - Special scales such as dual ranges, fine-division (with knife-edge pointer)
 - Stationary red pointer on the dial, or with external adjustment¹⁾
 - Maximum indicating pointer, external adjustment¹⁾ (≥ 100 mbar, ≥ 4 " WC)
 - Micro-adjustable pointer, mechanism aluminum
 - up to 10-times overrange protection, but
 - max. 40 bar (600 psi) for measuring flange $\varnothing 100$ mm (4"),
 - max. 2.5 bar (40 psi) for measuring flange $\varnothing 160$ mm (6")
 - Accuracy class 1.0 or .6 (EN 837-3) upon request
 - Other filling fluid for PSChG, e.g. silicone oil for temp. down to -40 °C (-40 °F) upon request
 - Version for temperatures $> +100$ °C ($> +212$ °F)
 - Electrical accessories, please see data sheets 3690, 9000 ff
- ¹⁾ If adjustable from outside: with acrylic glass resp. polycarbonate window

How to Order:

Model code:	PSCh, PSChG
Nominal case size:	100 (4"), 160 (6")
Wetted parts:	- 3, -4 or - 5 , compare left
Pressure range:	e.g. 0 - 4 bar or 250 mbar (acc. EN 837-3)
Connection:	G $\frac{1}{2}$ B ($\frac{1}{2}$ " BSP), $\frac{1}{2}$" NPT , or M 20x1,5 , for flange connection please specify flange type and size as on the following pages
Special options:	(see above)
Examples:	PSCh 100-3, 0-60 mbar, G $\frac{1}{2}$ B PSChG 100-4, 0-2.5 bar, DN 25

Dimensional Data and Weight

Bottom connection

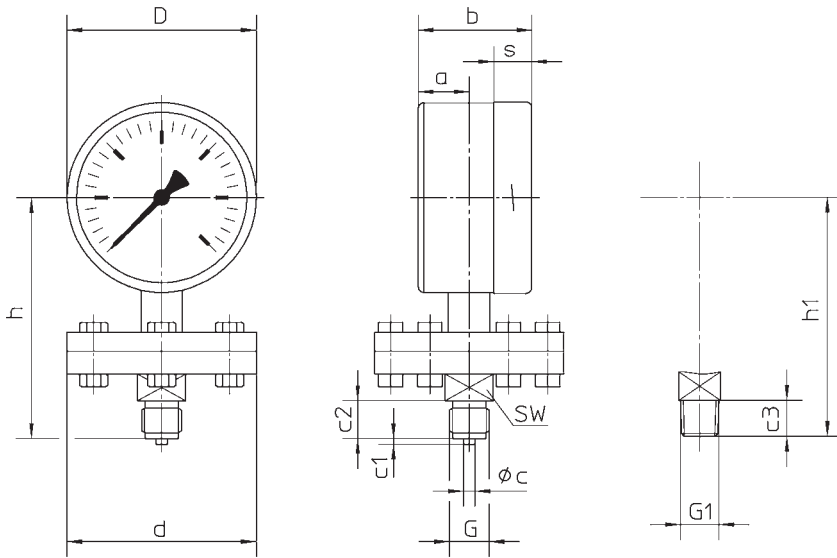

Dimensional Data (mm / inches) and Weight (kg / lb)

NCS	Measuring flange Ø d ¹⁾	a	b	c	c1	c2	c3	D	G	G1	h ^{±2}	h1 ^{±2}	s	SW	Weight (approx.) ²⁾	
															PSCh	PSChG
100 4	100	27	60	6	3	20	19	101 3.98	G ½ B ½" BSP	½" NPT	127 5	126 4.96	20	22	2.00	2.35
	4														6	4.41
160 6	160	40	78	.24	.12	.79	.75	161 6.34	G ½ B ½" BSP	½" NPT	157 6.18	156 6.14	.79	.87	3.70	3.95
	4														6	8.16
	160														2.70	3.60
	4														5.95	7.94
	6														4.30	5.10
															9.48	11.24

Flange 2707 a

(with double-end studs if requested)

Optionally available for flange 2707a:

Connection flange with thread connection G ½ B (½" BSP) or ½" NPT, with enlarged inlet orifice

Connection flange with welding connection for measuring flange Ø 100 mm (3.94")

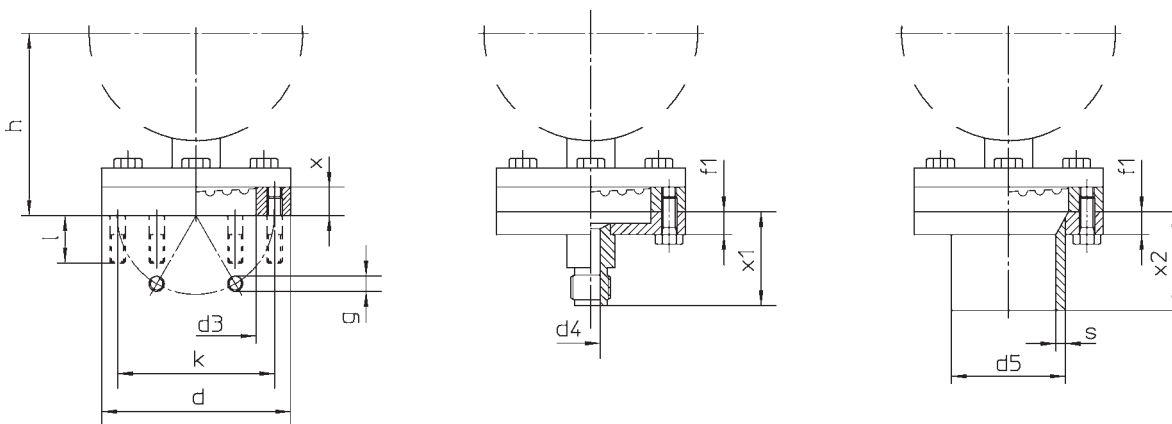

Dimensional Data (mm / inches) and Weight (kg / lb)

Measuring flange Ø d ¹⁾	d3	d4	d5 ³⁾	f1	g	h ^{±2}		k	l	x	x1	x2	s	Weight (approx.) ²⁾			
						PSCh 100	PSCh 160							PSCh 100	PSCh 100	PSCh 160	PSCh 160
100 4	63.5 2.50	10	60.3 2.37	12 .47	6 x M 8	96	126	83	25	15	46	50	5	1.85	2.20	2.60	3.50
						3.78	4.96	3.27				1.97	.20	4.08	4.85	5.73	7.72
160 6	123 4.84	.39	—	—	8 x M 8	96	126	140	.98	.59	1.81	—	—	2.75	3.00	3.60	4.40
								5.51				6.06	6.61	7.94	9.70		

¹⁾ nominal flange size

²⁾ For different pressure ranges and materials the weights differ considerably.

³⁾ other pipe diameters upon request

DIN EN 1092-1 Flange Connections DN 15, 20, 25 and 50, PN 10 to PN 40

Suitable for flanges in accordance with DIN EN 1092-1 type 11 (corresponding to former DIN 2633, 2635)

Measuring Flange-Ø d = 160 mm (6")

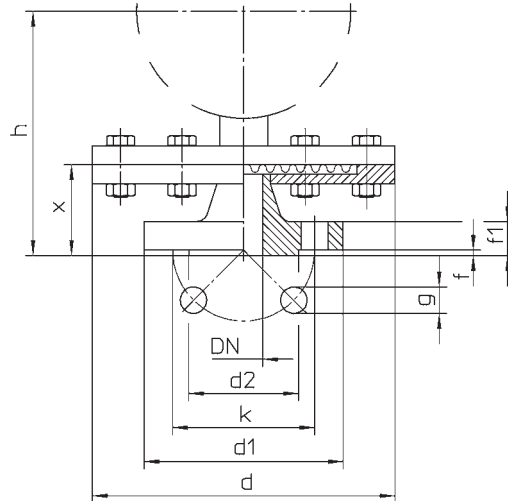

Dimensional Data (mm / inches) and Weight (kg / lb)

Measuring flange Ø d ¹⁾	DN	d1	d2	f	f1	g	h ^{±2}		k	x	Weight (approx.) ²⁾			
							PSCh 100	PSCh 160			PSCh 100	PSChG 100	PSCh 160	PSChG 160
160 6	15	95	45	2	16	4 x 14 4 x .55	127	157	65	46	4.25	4.55	4.90	5.75
	.59	3.74	1.77		.63		5.00	6.18	2.56	1.81	9.37	10.03	10.80	12.68
	20	105	58		18		129	159	75	48	4.65	4.95	5.35	6.20
	.79	4.13	2.28		.08		5.08	6.26	2.95	1.89	10.25	10.91	11.79	13.67
25	115	68	20	4 x 18	137	167	85	56	4.70	5.00	5.45	6.30		
.98	4.53	2.68	.79	4 x .71	5.39	6.57	3.35	2.20	10.36	11.02	12.01	13.89		
50	165	102	20	4 x 18	137	167	125	56	6.15	6.45	6.85	7.70		
1.97	6.50	4.02	.79	4 x .71	5.39	6.57	4.92	2.20	13.56	14.22	15.10	16.98		

Measuring Flange-Ø d = 100 mm (4")

DN 15, 20 and 25

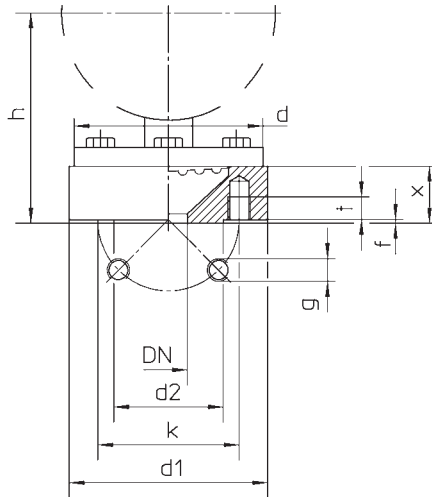

DN 50

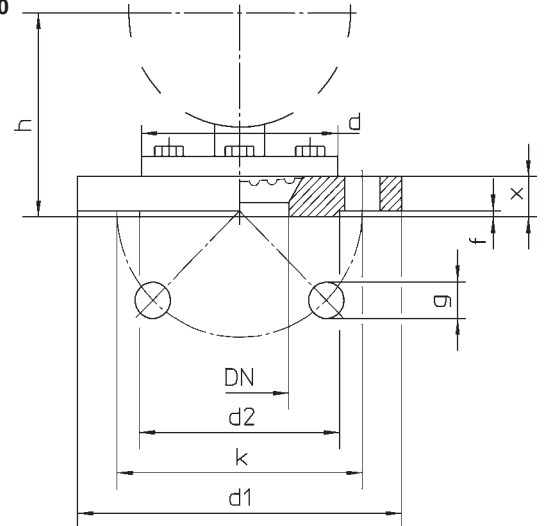

Dimensional Data (mm / inches) and Weight (kg / lb)

Measuring flange Ø d ¹⁾	DN	d1	d2	f	g	h ^{±2}		k	t	x	Weight (approx.) ²⁾			
						PSCh 100	PSCh 160				PSCh 100	PSChG 100	PSCh 160	PSChG 160
100 4	15	99	45	2	4 x M 12 ³⁾	106	136	65	12	25	2.55	2.85	3.15	4.00
	.59	3.90	1.77			4.17	5.35	2.56		.98	5.62	6.28	6.94	8.82
	20	105	58			75	2.60	2.90		3.20	4.05			
	.79	4.13	2.28			2.95	5.73	6.39		7.05	8.93			
25	115	68	85	22	3.05	3.35	3.65	4.50						
.98	4.53	2.68	3.35	.87	6.72	7.39	8.05	9.92						
50	165	102	125	20	3.85	4.15	4.45	5.30						
1.97	6.50	4.02	4.92	.79	8.49	9.15	9.81	11.68						

¹⁾ nominal flange size

²⁾ For different pressure ranges and materials the weights differ considerably.

³⁾ if requested with double-end studs M 12 x 45

ASME Flange Connections 1/2", 1" and 2", PN 150, 300, or 600 lb/sq.in.

ASME B 16.5 RF

Measuring Flange-Ø d = 160 mm (6")
PN 150 lb/sq.in.

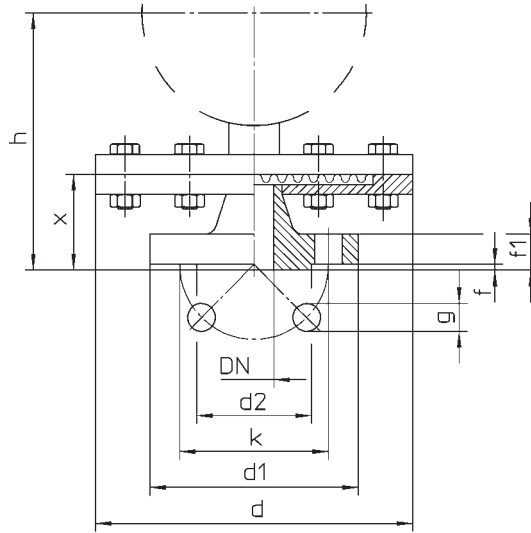

Dimensions (mm / inches) and Weight (kg / lb)

Measuring flange Ø d ¹⁾	DN	d1	d2	f	f1	g	h ^{±2}		k	x	Weight (approx.) ²⁾			
							PSCh 100	PSCh 160			PSCh 100	PSChG 100	PSCh 160	PSChG 160
160 6	1/2"	88.9 3.5	34.9 1.37	1.6 .06	11.1 .44	16 .63	137 5.39	167 6.57	60.3 2.37	56 2.20	3.75 8.27	4.00 8.82	4.40 9.70	5.20 11.46
	1"	108 4.25	50.8 2		14.3 .56		145 5.71	175 6.89	79.4 3.13	64 2.52	4.35 9.59	4.60 10.14	5.05 11.13	5.85 12.90
	2"	152 5.98	92.1 3.63		19 .75		19 .75	153 6.02	183 7.20	121 4.76	72 2.83	6.35 14.00	6.60 14.55	7.05 15.54

Measuring Flange-Ø d = 100 mm (4"), PN 150, 300 or 600 lb/sq.in.

DN 1/2" and 1"

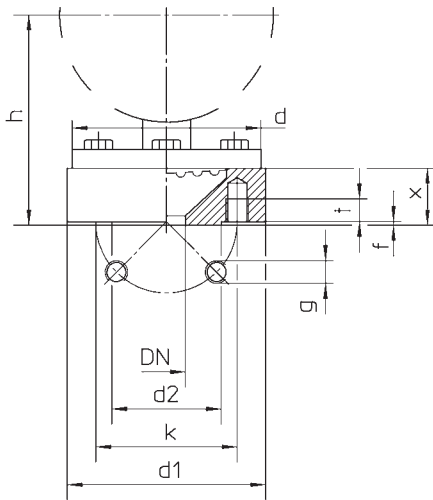

DN 2"

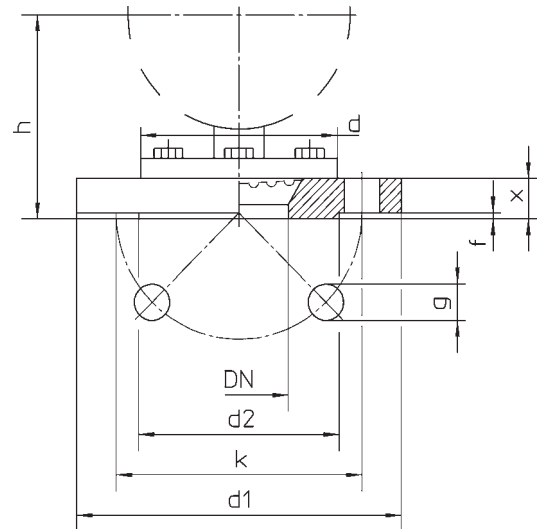

Measuring flange Ø d ¹⁾	DN	d1		d2	f		g	h ^{±2 5)}		k	t	x			Weight (approx.) ²⁾								
		150 lb/sq.in.	300 600 lb/sq.in.		150 300 600 lb/sq.in.	600 lb/sq.in.		for 300 lb/sq.in. NCS	for 300 lb/sq.in. NCS			150 300 600 lb/sq.in.	150 300 600 lb/sq.in.	300 600 lb/sq.in.	PSCh 100	PSChG 100	PSCh 160	PSChG 160					
100 4	1/2"	99 3.90	34.9 1.37	1.6 .06	6.4 .25	4 x UNF 2B	1/2 - 20	111	141	60.3	66.7	15	30	35	2.70	3.05	3.30	4.30					
	1"	108 4.25	124 4.88					50.8 2.0	4.37	5.55	79.4 3.13				88.9 3.5	5.95	6.72	7.28	9.48	3.40	3.75	4.00	4.90
	2"	152 5.98	165 6.50					92.1 3.63	4.06	5.2	121 4.76				127 5.0	8.60	9.15	9.92	11.68	3.90	4.15	4.50	5.30

¹⁾ nominal flange size

²⁾ For different pressure ranges and materials the weights differ considerably.

³⁾ 150 lb/sq.in.: 1/2 - 20 UNF - 2 B

⁴⁾ 300 and 600 lb/sq.in.: 8 x Ø 19 (.75")

⁵⁾ 150 and 600 lb/sq.in.: differences as of dimension "x"

Many other process connection types are available upon request, e.g. with female thread 1" BSP or union nut acc. to DIN 11851 et.al.