

## Contents

	Page		Page
1. Scope	1	7. Operation	7
2. Elastic Elements, Construction of Pressure Gauges and Chemical Seals	1	8. Maintenance and Repair	8
3. Selection Criteria	3	9. Electrical Accessories	8
4. Accessories	5	10. Storage	8
5. Set-up Options	6	11. Installation in potentially explosive areas	8
6. Installation	6	11.1 General Information	8
		11.2 Marking for the Explosion Hazard Areas	8

## 1. Scope

The information provided in these Operating Instructions relating to the selection, application, set-up options, installation and operation applies to pressure gauges with an elastic sensing element.

## 2. Elastic Elements, Construction of Pressure Gauges and Chemical Seals

### 2.1 Elastic Elements

#### Bourdon Tube Types:

##### C-Type Bourdon Tube

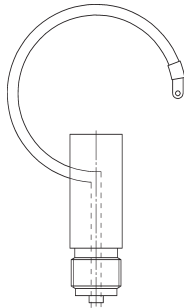

##### Helical Bourdon Tube

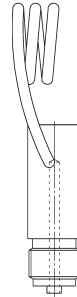

#### Diaphragm Type:

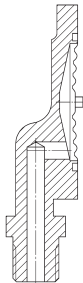
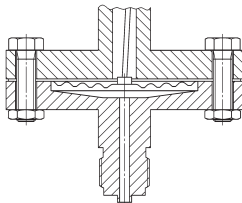

#### Capsule Type:

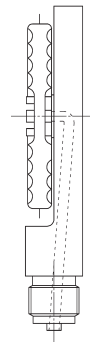

# Operating Instructions Pressure Gauges

## Selection, Set-up of Measuring Instruments, Mounting and Operating Instructions

### 2.2 Construction of Pressure Gauges

#### Pressure Gauge with C-type Bourdon Tube

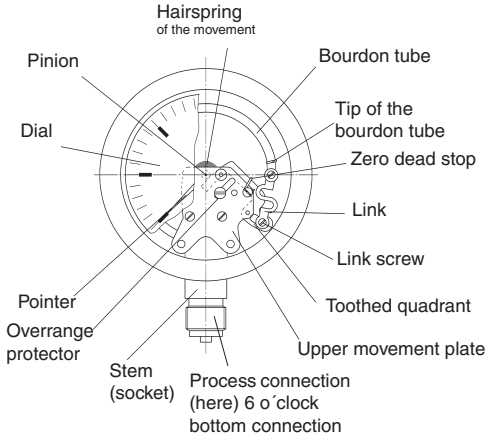

#### Pressure Gauge with Horizontal Diaphragm

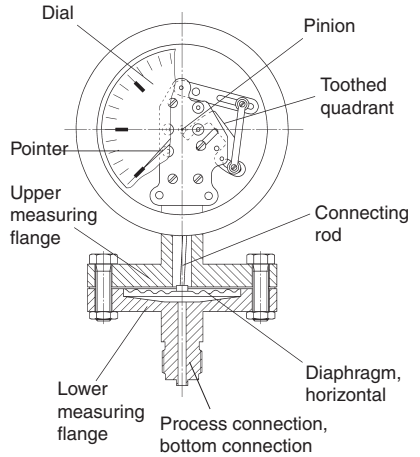

#### Pressure Gauge with Diaphragm Capsule

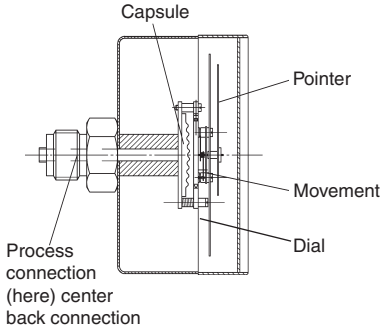

#### Pressure Gauge with Vertical Diaphragm

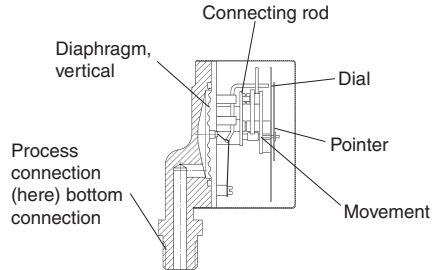

#### Pressure Gauge in line with Safety Requirements According to EN 837-1, S3 (formerly DIN 16 006 Part 1 and Part 2)

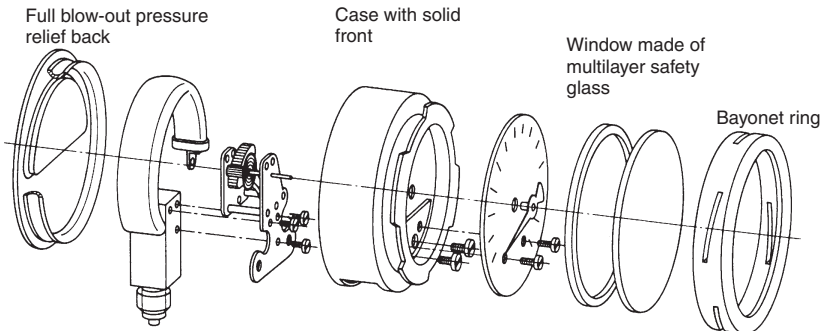

### 2.3 Types of Chemical Seal

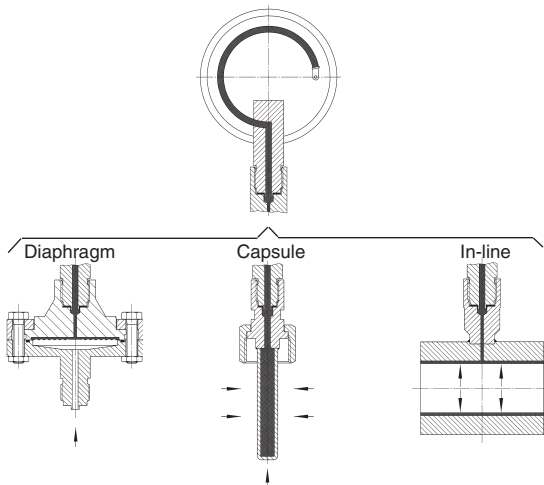

### 3. Selection Criteria

In each case the user needs to ensure that the proper pressure gauge was selected with respect to indicating range and design (resistance of the materials used against the pressure medium, atmosphere and temperature as well as resistance against overpressures, for example). The regulations valid for the particular application as well as EN 837-2 must be observed.

#### 3.1 Principles of measurement

The pressure gauges described in these Operating Instructions contain components which are subjected to elastic deformation when exposed to a pressure. This motion is transferred to a movement with a pointer. Because of their ruggedness and simple usage these pressure gauges are widely used throughout the industry. The elastic elements themselves are generally made of copper alloys or alloyed steel.

#### Pressure Gauges with Bourdon Tube

Bourdon tubes are oval tubes bent into a circular arc. The pressure which is to be measured acts upon the interior of the tube so that the tube's oval cross section becomes approximately circular. The edge stress produced through this deforming effect causes the arc of the Bourdon tube to open. The end of the Bourdon tube which is not affixed performs a motion, this motion being a measure for the pressure. For pressure ranges up to 40 bar Bourdon tubes bent into a circular arc over angle of 270 degrees are commonly used, for higher pressure ranges helical Bourdon tubes having several turns are employed. Bourdon tubes have a relatively low restoring force. This must be taken into account when using additional accessories like indicating pointers, limit switches or potentiometric transducers since these will affect the readings obtained. Pressure gauges with a Bourdon tube can normally only be protected in a limited way against overloading by supporting the elastic element at a specific pressure limit.

Bourdon tube pressure gauges of accuracy grades between 0.6 and 2.5 are commonly used for measurements in the range between 0.6 bar to 4000 bar. The influence of temperature changes on the indication depends chiefly on the temperature coefficient (TEC= change in stiffness caused by change in temperature) that is specific for the elastic modulus of the Bourdon tube. Depending on the material used, the accuracy error caused by temperatures differing from the reference temperature will amount to between 0.3 % and 0.4 % per 10 K.

#### Diaphragm Pressure Gauges

The diaphragms are corrugated in circles. The pressure is applied to one side of the diaphragm. The degree of flexing is a measure for the pressure. Diaphragms have a relatively high restoring force. For this reason the influence of additional accessories is less compared to gauges using Bourdon tubes. Through the annular fixing arrangement for the diaphragm it is less sensitive to vibrations. By supporting-means it is possible to protect the diaphragms against severe overloading. By means of coatings or foils in front of the diaphragm, the diaphragm itself may be protected against corrosive pressure media. Diaphragm gauges may be used with advantage also for highly viscous and crystallising pressure media since through extended connection bores, open connection flanges or purge holes optimum cleaning conditions may be provided for.

There are gauges with a horizontally arranged diaphragm and gauges with a vertically arranged diaphragm, i.e. where the diaphragm is placed in parallel to the dial. Generally for pressure ranges below 0.6 bar diaphragms with a diameter of 160 mm are used for pressure gauges with horizontal diaphragm, whereas diaphragms with a diameter of 100 mm are used for higher pressure ranges. Owing to the annular fixing arrangement of the diaphragm the inaccuracy caused by temperature changes is significantly greater compared to gauges with a Bourdon tube. Diaphragm pressure gauges are applied for pressure ranges between 10 mbar up to 25 bar with standard accuracy grades of 1.6 or 2.5, in exceptional cases also 4.0.

# Operating Instructions Pressure Gauges

## Selection, Set-up of Measuring Instruments, Mounting and Operating Instructions

### Capsule Pressure Gauges

A diaphragm capsule consists of two circular corrugated diaphragms or a diaphragm and a base plate joined in a pressure-tight matter at the rim. The pressure is introduced at the centre of one of the diaphragms and acts upon the inside of the capsule. The resulting movement is a measure for the pressure. Capsule pressure gauges are not suited for liquid pressure media. They are available for pressure ranges from 2.5 mbar to 600 mbar in accuracy grades from 0.6 to 1.6. The deviation in the readings in response to temperature changes amounts to between 0.3 % and 0.4 % per 10 K depending on the material used.

### 3.2 Pressure Ranges

The operating pressure should be in the mid. third of the pressure range specified for the gauge. The maximum pressure load should not exceed 75 % of full scale value at static loads, or 65 % of full scale value for pulsating loads. Refer to EN 837-2.

### 3.3 Accuracy Limits

The accuracy limits for pressure gauges have been defined in EN 837-1 (Bourdon gauges) and EN 837-3 (capsule and diaphragm gauges) (formerly DIN 16 005). Pressure gauges belonging to grade 0.1 to 0.6 and higher are preferably used in laboratories and workshops. Pressure gauges of grades 1.0 and 1.6 are mainly used for measurements on machines and production facilities. Pressure gauges belonging to grade 2.5 and 4.0 are used in monitoring measurements where accuracy requirements are not that high.

### 3.4 Conditions of Usage

When selecting pressure gauges the selection criteria and installation recommendations in accordance with EN 837-2 (formerly DIN 16 005 Part 1 and Part 2) as well as the instructions provided here, especially in para. 3.4.1, 3.4.2 and 5. must be observed. The use of pressure gauges which do not meet the requirements encountered in practice can cause great consequential damage.

#### 3.4.1 Pressure Media Properties

##### March of Pressure

The actual elastic element must not be exposed suddenly to rapid pressure changes or pressure spikes. In the case of pressure spikes the pressure limits specified for the gauge must not be exceeded.

If required overload protection means (refer to para. 4) must be provided upstream. Pressure changes in excess of 10 % of the full scale value per second will impair the readings. Moreover, this will severely impair the service life of the gauges. In such cases attenuators must be provided. Through throttling components (restrictor screw or adjustable snubber) the cross section at the inlet can be much reduced in order to delay the transmission of the pressure change to the gauge. Fitting of a throttling line (a line with a reduced cross section) ahead of the gauge is also possible. In both cases the increased risk of accumulating contamination is a disadvantage. Attenuating components at the movement will only delay the movement of the pointer. Filling the case with fluids will attenuate the movement of the elastic element and will help to reduce wear on moving parts.

### Temperature

If the temperature of the pressure medium at the point where it is measured deviates from the operating temperature specified for the pressure gauge (refer to para. 7 as well as EN 837-1, -2, -3) then a sufficiently long measuring line, a siphon or a chemical seal with a capillary line must be mounted to the pressure gauge. The influence on the reading owing to temperatures deviating from +20 °C must be observed.

### Highly Viscous, Crystallising and Solid-containing Media

For measurements on highly viscous, crystallising or solid-containing pressure media, the use of diaphragm or Bourdon tube pressure gauges with attached chemical seal (refer to para. 4.4) is recommended.

### Corrosive Pressure Media

If corrosive pressure media can be kept away by separating means from the elastic element, then standard gauges may be used. Otherwise the selection of a suitable material is mandatory, whereby the user must provide to the manufacturer all information on the materials which under the given conditions are compatible with the pressure medium, refer to EN 837-2, 4.3. Because of the restricted choice of materials for the elastic elements, diaphragm pressure gauges with a protective lining will possibly have to be used, or chemical seals made of pressure media resistant materials need to be mounted to a Bourdon tube pressure gauge.

### Safety

There is an increased risk combined with gases and fluids under high pressure, for example. In case of developing leaks or bursting of pressurised components, persons in front of the viewing window of the instrument must not be injured by the pressure medium escaping to the front.

Safety pressure gauges with a blow-out device on the rear, fitted for example with a pressure relief on the back, will here offer the required degree of protection (refer to the Fig. on the bottom of page 2).

When using hazardous pressure media, for example

- oxygen
- acetylene
- combustible substances
- toxic substances

as well as refrigerating units, compressors etc. the applicable regulations must be observed.

In accordance with EN 837-1, 9.7 fluid filled pressure gauges must be equipped with blow-out devices (designated S1, or also S2 resp. S3 in according to EN 837-1).

#### 3.4.2 Ambient Conditions

##### Vibrations

If an exposure of the pressure gauge to vibrations can not be avoided by way of a suitable installation, gauges equipped with damping devices for the movement or gauges with a fluid filling must be used.

# Operating Instructions Pressure Gauges

## Selection, Set-up of Measuring Instruments, Mounting and Operating Instructions

### Ambient Temperature

The accuracy limit given on the dial applies at a reference temperature of +20 °C. Deviating temperature will have an influence on the reading. The magnitude of the influence will depend on the principle of measurement used (refer to para. 3.1). At outdoor services, the prevailing ambient conditions must be taken into account through the selection of a suitable gauge or by introducing suitable protection means in order to prevent the formation of ice on the pressure gauge at temperatures below 0 °C, for example. For liquid filled instruments it has to be considered that the viscosity of the fluid will increase as the temperature drops causing a delayed reading. The ambient temperature needs also to be taken into account regarding the maximum allowed operating temperature specified for the pressure gauge.

### Corrosive Atmosphere

For services at corrosive atmospheres suitable casings and components made of corrosion resistant materials must be provided. Also special surface finishing may help to protect the outside of the pressure gauges.

## 4. Accessories

### Shut-off Fittings for Pressure Gauges

It is recommended to fit shut-off devices between the measuring point and the pressure gauge. This will allow an exchange of the pressure gauge and checks on the zero setting while the system remains operative.

Depending on the application either cocks or valves are used. Cocks have three positions:

- Vent: The supply line is shut-off and the gauge is connected to the atmosphere. The zero setting may be checked.
- Operation: The supply line is open, the gauge is pressurised.
- Blow-out: The supply line is open, the pressure medium is allowed to escape into the atmosphere. The gauge is not working.

In the case of valves (according to DIN 16 270 and DIN 16 271, for example) a venting screw is usually provided between valve seat and pressure gauge. Venting into the atmosphere must be arranged in a way that any persons present close by are not endangered by the escaping pressure medium. Potential hazards to the environment must be avoided. In certain applications (steam boilers, for example) the shut-off fitting must have a test port so that the pressure gauge can be checked without having to remove it from the system.

### Holding Devices for the Pressure Gauge

If the line to which the gauge is connected is not strong enough to support it without introducing vibrations, then a suitable holding device for the pressure gauge should be provided.

### Siphons

Use sufficiently long lines ahead of the pressure gauge or siphons to protect the shut-off fittings and the gauge against being heated up by hot pressure media (steam, for example).

### Chemical Seals

In the case of aggressive, hot, highly viscous or crystallising pressure media, chemical seals may be used as separating means ahead of Bourdon gauges in order to prevent the ingress of such pressure media into the elastic element. A neutral fluid serves the purpose of transmitting the pressure to the elastic element. The fluid must be selected depending on the measuring range, temperature, viscosity and other influences. Special emphasis must be placed on the compatibility of the fluid with the pressure medium.

Chemical seals are available in a variety of different types, refer to sketches in para. 2.3, whereby the diaphragm seal is most popular.

In-line seals and flange type diaphragm seals must be mounted together at works suitable for the fitting position at the measuring point.

The connection between the pressure gauge and the chemical seal must not be separated.

Potential sources of inaccuracy by installing a chemical seal ahead of the pressure gauge need to be considered.

### Overpressure Protection Facilities

If for operational reasons the pressure range of the gauge had to be chosen below the maximum operating pressure, overpressure protection devices ahead of the pressure gauge may be used to protect it against damages. In the event of pressure spikes the overrange protector will shut-down immediately, but only gradually at slow rising pressure. The closing pressure which needs to be set up therefore depends on the specific pressure change with time.

However, highly viscous and much contaminating pressure media may impair proper operation of the overrange protector or render these ineffective.

Capsule and diaphragm pressure gauges may be so designed that they themselves will be capable of resisting overpressures (up to a factor of 3, 5 or 10) without additional devices.

# Operating Instructions Pressure Gauges

## Selection, Set-up of Measuring Instruments, Mounting and Operating Instructions

Tabelle 1

State of the pressure medium	fluid			gaseous		
	fluid	partly degassing	fully degassing	gaseous	partly condensed (humid)	fully condensed
State of the filling in the measuring line	condensate	boiling fluids	"liquid gases"	dry air	moist air flue gas	water vapour
Examples						
a) Pressure gauge above the measurement port	1	2	3	4	5	6
b) Pressure gauge below the measurement port	7	8		9	10	11

Arrangements 3, 4, 5, 7, 8 and 11 are to be preferred

### 5. Set-up Options

#### General

Well proven measuring arrangements and proposals for components are detailed in VDE/VDI 3512 Sheet 3. Shown in Table 1 is an overview of some arrangements.

#### Pressure Measuring Ports

The pressure measuring port should be located at a point where the flow is not impaired in any way and where constant conditions can be ensured for the measurements. It is recommended to provide a sufficiently large bore at the point of the pressure measurement and to provide some means for shutting the pressure measuring port off.

#### Measuring Line

The connection between pressure measuring port and pressure gauges is the measuring line. The inside diameter of this measuring line should be sufficiently wide in order to avoid the risk of blockages. The measuring line should have a steady slope (recommended is a slope of 1:15). With gases as the pressure medium a drain should be provided at the lowest point and with high-viscosity fluids a vent should be provided at the highest point. In the case of gases containing solids or fluids separators should be provided which may be demounted from the running system for emptying. The measuring line should be designed and fitted in a way that it will be capable of sustaining the occurring loads caused by expansion, vibration or thermal effects.

#### Shut-off Fittings

Shut-off fittings at the pressure gauge serve the purpose of checking the zero setting or exchanging the pressure gauge while the system remains operational (refer to para. 4).

#### Pressure Gauge

The pressure gauge needs to be mounted so that it will not be subjected to vibrations and shocks and so that the dial can be read easily. When reading the dial parallax errors should be avoided. It must be ensured that possibly

present blow-out devices of the pressure gauge are not blocked (refer to EN 837-1, 9.7). The pressure gauge must be arranged in such a manner that the temperature of the gauge will not drop below or exceed the permissible operating temperature range (refer also to para 3.4.1, and 7). In doing so, the influences of convection and thermal radiation should be taken into account. Whenever the elastic element of a pressure gauge will be filled with water or a water mixture the instrument must be protected against frost. Usually the pressure gauge will be fitted with the dial arranged vertically. In all other cases the position indicating symbol according to EN 837 (formerly DIN 16 257) applies. A difference in height between the port at which the pressure is measured and the pressure gauge will cause a shift at the beginning of the reading if the pressure medium in the measuring line is of a different density compared to the ambient air. This shift  $\Delta p$  at the beginning of the reading results from the difference in density ( $\rho_M - \rho_L$ ) and the difference in height  $\Delta h$ :  $\Delta p = 10^{-5} \cdot (\rho_M - \rho_L) \cdot g \cdot \Delta h$

$$\begin{aligned} \Delta p &= \text{Shift at the beginning of the reading} && (\text{bar}) \\ \rho_M &= \text{Density of the pressure medium} && \text{kg/m}^3 \\ \rho_L &= \text{Density of the air (1.205 at 20 °C)} && \text{kg/m}^3 \\ \Delta h &= \text{Difference in height} && \text{m} \\ g &= \text{Acceleration due to gravity} && \text{m/s}^2 \\ &&& (\text{mean acceleration due to gravity } = 9.81 \text{ m/s}^2) \end{aligned}$$

The reading is reduced by  $\Delta p$  if the pressure gauge is located above the pressure measurement port and increased by  $\Delta p$  if below the pressure measurement port.

### 6. Installation

The installation of pressure gauges should be left to skilled staff. As to the measurement arrangement refer to para. 5. During installation or removal never apply any forces to the case of the pressure gauges; instead apply the wrench to the wrench flats provided. It must be ensured that the matching process connection has been selected (nominal width, suitable sealing face, if required). In order to position the pressure gauge so that it may be read perfectly the use of a clamping

# Operating Instructions Pressure Gauges

## Selection, Set-up of Measuring Instruments, Mounting and Operating Instructions

sleeve or a union nut is recommended. In the case of flange joints the pressure gauge is placed on the mating flange and the flanges are joined using suitable bolts. It must be ensured that the bolts are tightened firmly. The joints must be leaktight. For this reason it is mandatory that suitable gaskets made of a material resistant to the pressure medium will be used in the connections. For sealing connections with a parallel thread, for example, flat gaskets in accordance with EN 837-1 or profile seals must be fitted, or on the other hand the corresponding sealing lens has to be provided in case of a high pressure connection. Tapered threads (for example NPT threads) are sealed off with additional sealants like PTFE tape, for example (refer to EN 837-2)

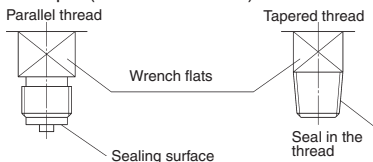

For pressure gauges with a pressure relief vent of  $\varnothing$  13 mm at the top of the case it is recommended for pressure ranges  $< 6$  bar to cut off the nipple at the filling plug so that the gauge can be vented in order to compensate the internal pressure. If the pressure gauge is located below the pressure measurement port, the measuring line should be purged well before starting operation so as to remove any foreign objects which might be present in the line. During pressure tests on pipes or vessels, the pressure gauge must not be exposed to excessively high pressures as indicated by the pressure limit indicating mark ▼ on the dial, resp. the limits for a static pressure specified for the pressure gauge must not be exceeded (refer to para. 7). When using diaphragm gauges the clamping bolts for the upper and lower flange must not be loosened. In the case of instruments with attached chemical seals the connection between gauge and chemical seal and possibly also the connection between chemical seal and capillary line must not be disconnected.

Before disconnecting and removing the pressure gauge unit from the measuring point it must be depressurized first. If required the pressure in the measuring line must be relieved. Residues of the pressure medium in pressure gauges which have been removed may present a hazard to personnel, facilities and the environment. For this reason suitable safety precautions must be introduced (Electrical accessories: refer to para. 9).

### 7. Operation

Shut-off devices may only be opened slowly in order to avoid sudden pressure spikes during start-up.

#### Specified Usage

The usable range for static loads is indicated by ▼ on the dial of many pressure gauges (refer to EN 837-1, EN 837-3).

Bourdon tube pressure gauges of nominal case size of 100, 160 or 250 may be subjected to the respective full scale pressure if the load is static. If the pressure load is of a pulsating nature, pressure peaks amounting to only 0.9 of the full scale pressure are permissible, and

for the pressure ranges of 0/2500 bar and 0/4000 bar pressures amounting only to 2/3 of the full scale pressure may be applied. Bourdon tube pressure gauges can be overloaded up to 1.3 of their full scale value (instruments 0/2500 bar and 0/4000 bar can only be overloaded up to their full scale value!).

Bourdon tube pressure gauges having a nominal size of 40, 50, 60, 63, 80 and 72x72 may only be subjected to pressures up to 3/4 of the full span if the pressure is static and if the pressure is of a pulsating nature the maximum load is restricted to 2/3 of the full scale value, and the full scale pressure may be applied only briefly.

In the case of diaphragm pressure gauges with a vertical diaphragm pressures up to the full scale value may be applied if static, and if the pressure is of a pulsating nature, the limit will be 0.9 of the full scale level.

Diaphragm pressure gauges with a horizontal diaphragm can sustain overpressures up to five times their full scale value (custom-built instruments even more), but a pressure of 40 bar must never be exceeded.

Capsule pressure gauges can also be operated at their specified full scale pressure provided the pressure is static. If the pressure pulsates, the maximum load is only 0.9 times the full scale value. Just like Bourdon tube pressure gauges they are able to sustain overpressures up to a factor of 1.3 (custom-built instruments can handle even higher overpressures).

#### Zero Check

In order to check the zero setting of the pressure gauge during operation of the system, the required shut-off device has to be closed (refer to para. 4) and the pressure in the gauge has to be relieved. The pointer must come to rest within the zero range indicated by I. If the pointer comes to rest outside of this range then a persisting deformation of the elastic element must be assumed so that the gauge will have to be checked in order to avoid accidents owing to incorrect measurements. In such a case the pressure gauge should, for this reason, be replaced and returned to the manufacturer for checking and repair if required.

#### Pressure Range Check

If the readings supplied by the pressure gauge need to be checked while the remainder of the system is operating, the pressure gauge has to be separated from the process via the required shut-off device with test port (refer to para. 4) and a test pressure has to be applied to the gauge. The error limits according to EN 837-1 resp. EN 837-3 apply.

#### Temperature Resistance

The permissible operating temperature for the pressure gauge must not be exceeded.

The temperature resistance respectively the permissible operating temperature ranges are generally from  $-40^{\circ}\text{C}$  to  $+60^{\circ}\text{C}$  (compare to EN 837-1 and EN 837-3), at which unfilled gauges with a silver-brazed bourdon tube are capable up to  $+100^{\circ}\text{C}$  or argon arc welded bourdon tube are capable up to  $+200^{\circ}\text{C}$  in stainless steel cases. Special versions which are labelled accordingly (tA / tR) can be suitable for higher temperatures.

Note: These are only information on the temperature



# Operating Instructions Pressure Gauges

## Selection, Set-up of Measuring Instruments, Mounting and Operating Instructions

resistance of the materials respectively the soldered joints or welded seams. The information on indication errors due to deviations from the reference temperature have to be regarded. More information can be found in our model overview 1000.

### Cleaning Temperature

Also when purging the measuring line the permissible operating temperature for the pressure gauge (refer to above) must not be exceeded. If required the gauge will have to be shut-off or removed. In the case of pressure gauges with attached chemical seals the maximum cleaning temperature  $t_R$  must not be exceeded.

### 8. Maintenance and Repair

Generally pressure gauges will not require any maintenance. These instruments may only be repaired by the manufacturer. Before returning an instrument for repair all parts of the instrument in contact with the pressure medium must be cleaned with care, especially when hazardous pressure media were used before (refer also to para. 6). It is a good idea to always include with the repair order a description of the pressure medium resp. a Declaration of Contamination.

### 9. Electrical Accessories

The electrical connections should be made only by skilled staff and qualified personnel. Instruments equipped with electric accessories have an adhesive label from which it is apparent how the instrument is to be electrically connected. Load limits must be observed. Exceeding of load limits could cause greater damage. During installation, initial operation and operation of the instruments the national and international safety regulations (VDE 0100, for example) must be observed.

It must be ensured that the cable diameters match the nominal widths of the sealing inlets of the cable feedthroughs. Screwed joints must be tightened firmly.

Compliance with the certified protection standards can only be ensured in this way. In the case of designs with right-angled plug connectors, universal plug connectors or terminal boxes, the centrally arranged fixing screws must be tightened manually.

In connection with the DMU type pressure transducers shielded cables must be used throughout, the shield of which must be connected to housing or the ground terminal on the right-angled plug connector so as to ensure full electromagnetic compatibility (EMC).

In the case of equipment with a magnetic contact it must be noted that the CE mark in accordance with EMC guidelines will only apply if a switching frequency of 5 actuations per minute is not exceeded.

If specified, a suitable output unit or multifunctional relay must be used (for example for instruments with inductive limit switches). The current Operating Instructions must be observed.

### 10. Storage

When keeping pressure gauges in stock before mounting they should be left in the original packaging and should be maintained in stock well protected against damage by external influences. If the pressure gauge was taken out of its packaging and inspected briefly (for testing, for example) it should be carefully placed back in the same packaging before returning it to stock. While the pressure gauge is in stock the general temperature limits of  $-40\text{ }^{\circ}\text{C}$  and  $+60\text{ }^{\circ}\text{C}$  should not be exceeded (refer to EN 837-1 and EN 837-3).

If in doubt or if anything remains unclear please get in touch with the manufacturer.

### 11. Installation in potentially explosive areas

#### 11.1 General Information

Pressure Gauges are mechanical pressure measuring instruments and do not show any ignition sources when operating as intended. Versions that are made of stainless steel and contain laminated safety glass are suitable for the use in areas of category 2 and 3 according to ATEX-Standard 94/ 9/EG.

Only pressure measuring instruments with integrated construction type proved deflagration volume protection, our model Adapt-FS, are suitable for the use as category-1 instrument.

This protection system prevents a flame penetration at deflagration of explosive vapor-air, respectively gas-air mixtures of explosion hazardous IIA, IIB and IIC in an upstreamed volume of a maximum of 0.2 l.

The deflagration volume protection "Adapt-FS" is certified



IIG IIC PTM 12 ATEX 4001 X



on condition that the operating pressure does not exceed 1.1 bar abs. and the operating temperature does not exceed  $60\text{ }^{\circ}\text{C}$  ( $140\text{ }^{\circ}\text{F}$ ).

To avoid warming up the measuring elements of bourdon tube pressure gauges a dynamic load with gaseous media is not allowed!

#### 11.2 Marking for the Explosion Hazard Areas

Pressure gauges **without** limit switch contacts for use in hazardous areas are marked as follows:

Example: Bourdon Tube Pressure Gauge Type RCh100-3, manufacturer Instruments To Industry Ltd.

	Euro Works, Hawksley Street, Oldham OL8 4PQ
	Bourdon Tube Pressure Gauge Type RCh 100-3
	II 2Gc II 2Dc
	Temperature range $-25\dots+75\text{ }^{\circ}\text{C}$