

Thermowells according to DIN 43772

**Form 8 (Fabricated) and Form 9 (Solid Drilled),
with Male Thread Process Connection
for Thermometer Stem Type A3 (with Union Nut)**

Model

**SF8
SF9**

Application

Thermowells are applied to protect thermometer stems against difficult chemical and / or mechanical process conditions. Furthermore it is far easier to dismount a thermometer e.g. for repair or other reasons when a thermowell stays at the measuring point.

Thermowells form 8 (model SF8) and 9 (model SF9) acc. to DIN 43772 replace the thermowells form CD and CE acc. to DIN 16179 that have been part of our stem types A8 and A10 (compare former data sheet 8300).

The solid drilled version SF9 is suitable for difficult process conditions (pressure, temperature, flow rate, medium), model SF8 for low to medium load.

Standard Configuration

Process Connection

G ½ B (½" BSP male) or G ¾ B (¾" BSP male)

Material

Model **SF8**: 316 stainless steel (1.4571) or brass¹⁾

Model **SF9**: 316 stainless steel (1.4571),
alloy steel 1.7335²⁾, or carbon steel 1.0503³⁾

Instrument Connection

Male thread connection G ½ B (½" BSP-M) or G ¾ B (¾" BSP-M)

Inside Diameter (d1)

SF8: Ø 7 mm / .27" (Outside-Ø 12 mm [.47"] – G ½ B x G ½ B,
G ¾ B x G ¾ B)

Ø 9 mm / .35" (Outside-Ø 14 mm [.55"] – G ½ B x G ½ B,
G ¾ B x G ¾ B)

Ø 11 mm / .43" (Outside-Ø 14 mm [.55"] – G ½ B x G ½ B,
G ¾ B x G ¾ B)

Ø 13 mm / .51" (Outside-Ø 16 mm [.63"] – G ¾ B x G ¾ B)

SF9: Ø 7 mm / .27" (Outside-Ø 17 mm [.67"] – G ½ B x G ½ B,
G ¾ B x G ¾ B)

Ø 9 mm / .35" (Outside-Ø 17 mm [.67"] – G ½ B x G ½ B,
G ¾ B x G ¾ B)

Ø 11 mm / .43" (Outside-Ø 17 mm [.67"] – G ½ B x G ½ B,
Outside-Ø 19 mm [.75"] – G ¾ B x G ¾ B)

Ø 13 mm / .51" (Outside-Ø 20 mm [.79"] – G ¾ B x G ¾ B)

Thermowell Length L

101, 138, 198, 288, 438 mm (compare overleaf)
3.98", 5.43", 7.79", 11.34", 17.24"

Insertion Length U1

73, 110, 170, 260, 410 mm (compare overleaf)
2.87", 4.33", 6.69", 10.24", 16.14"

Temperature Limitations

Process temperature max. +600 °C (1,112 °F) for 316 stainl. steel (1.4571), with further limitations depending on thermowell version (dimensions, material) and operation conditions (pressure, temperature, flow rate, medium); load diagram see DIN 43772

Max. Allowed Working Pressure (at Static Pressure)

SF8: Brass max. 25 bar, 316 stainl. steel (1.4571) max. 40 bar,

SF9: 316 stainl. steel (1.4571) max. 150 bar,

with further limitations depending on thermowell version (dimensions, material) and operation conditions (pressure, temperature, flow rate, medium); load diagram see DIN 43772

¹⁾ 2.0401, CuZn36 Pb3

³⁾ carbon steel (non alloy quality steel) C45

²⁾ alloy special steel 13 CrMo 44

Form 8, model SF8



(Fabricated, i.e. screw fitting welded to the thermowell resp. soldered when material = brass)

Form 9, model SF9



(Solid drilled, i.e. completely manufactured from one piece)

Special Options

- Instrument connection M 20x1.5 (instead of G½B) or M27x2 (instead of G¾B); others upon request
- Other thermowell diameter or length upon request
- Other materials upon request
- Inspection certificate for the material / stamp confirmation certificate upon request
- Models CD or CE acc. DIN 16179, data sheet 8300, upon request

How to Order:

Please note the data sheet of the thermometer for the information about how to order the thermometer and stem. Additionally requested ordering information for the thermowell (separate item):

- Model: **SF8 or SF9**
- Inside-Ø d1: **7, 9, 11, or 13 mm**
(.27", .35", .43", or .51")
- Instrument connection: **G ½ B (½" BSP-M), G ¾ B (¾" BSP-M)**
(others see above)
- Process connection: **G ½ B (½" BSP-M), G ¾ B (¾" BSP-M)**
- Length: **Length L and insertion length U1**
- Material: SF8 **1.4571 or brass**
SF9: **1.4571, 1.7335²⁾, or 1.0503³⁾**

Examples for Ordering Information:

- SF8, d1=9, G ¾ B x G ¾ B, L=288, U1=260, 1.4571
- SF9, d1=11, G ½ B x G ½ B, L=198, U1=170, 1.7335



INSTRUMENTS TO INDUSTRY LTD

Instrument House • Knowsley Industrial Park • Liverpool L33 7UZ • UK
Phone: +44 (0) 151 546 4943 • Fax: +44 (0) 151 548 6262
www.itruk.com • sales@itruk.com

8312

8/03

Versions, Dimensions and Weight

Thermowell form 8,
model SF8,
fabricated

Thermowell form 9,
model SF9,
solid drilled

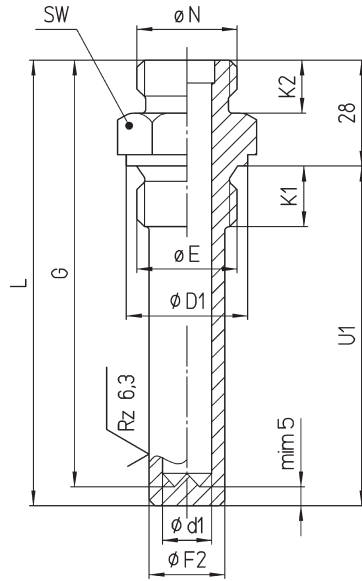
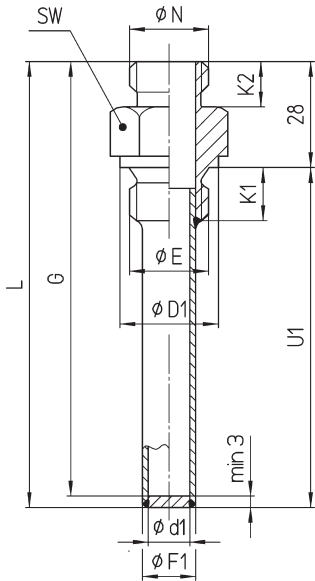

Suitable thermometer stem A3 with union nut,
compare data sheets 8210, 8220, 8230, 8240:

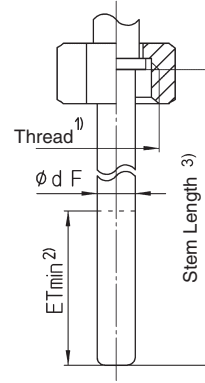

- 1) Union nut = suitable for thermowell instrument connection N
- 2) ETmin, the minimum immersion length of the stem (= L2 acc. DIN EN 13190) has to be considered when choosing thermowell and stem, compare table below resp. data sheet of the thermometers and stems.
- 3) corresponding to L1 acc. to DIN EN 13190

Thermowell Diameter (mm / inches) and Connections

Inside- Ø d1	SF8		Instrument connection (stem) N	Process connection E	D1	K1	K2	SW
	Outside- Ø F1	Outside- Ø F2						
7/.27	12/.47	17/.67	G 1/2 B 1/2" BSP-M	G 1/2 B 1/2" BSP-M	26 1.02	14 .55	12 .47	27 1.06
9/.35	14/.55							
11/.43								
7/.27	12/.47	17/.67	G 3/4 B 3/4" BSP-M	G 3/4 B 3/4" BSP-M	32 1.26	16 .63	14 .55	32 1.26
9/.35	14/.55							
11/.43	19/.75							
13/.51	16/.63							

Minimum Immersion Length ETmin* (mm / inches)

Ø dF A3	Rigid stem or capillary line ≤ 5 m		Capillary line > 5 m to max. 15 m**	
	≤ 500 °C ≤ 932 °F	> 500 °C > 932 °F	≤ 500 °C ≤ 932 °F	> 500 °C > 932 °F
6 .24	120 4.72	285 11.22	190 7.48	570 22.44
8 .31	75 2.95	165 6.50	115 4.53	320 12.60
10 .39	45 1.77	105 4.13	80 3.15	200 7.87
12 .47	35 1.38	75 2.95	53 2.09	150 5.90

* corresponding to L2 acc. to DIN EN 13190
** not for all temperature ranges!

Thermowell Length SF8, SF9 (mm/inches)

L ±1	Insertion length thermowell U1 ±1	G +1 0
101/3.98	73/2.87	96/3.78
138/5.43	110/4.33	133/5.24
198/7.95	170/6.69	193/7.60
288/11.34	260/10.24	283/11.14
438/17.24	410/16.14	433/17.05

Suitable Stem Length Stem Type A3 (mm/inches)

for SF8 (Stem length = G)	for SF9 (Stem length = G - 3 mm / .12")
96/3.78	93/3.66
133/5.24	130/5.12
193/7.60	190/7.48
283/11.14	280/11.02
433/17.05	430/16.93

The information in this leaflet is given in good faith, but we reserve the right to make changes without notice.